

PART NUMBER
IPSWDHD-MW

CATEGORY
DISPLAYS

Features

Display / Clock

1920 x 720 high resolution
full-color LCD screen.
Angled display to reduce glare.

Microphone

Hands-free two-way intercom.

Flashers

RGB flashing LED bar.
Customize for additional
visual messaging in any color.

Audio

8" high-efficiency speaker audio coverage
up to 600ft². Digitally enhanced bass.

Peripheral Integration

Connect a strobe, motion sensor,
electronic lock, call button, etc.

Software

ClockWise Campus software included.
Compatible with approved third-party
software.

SIP Integration

SIP-enabled.
Easily interfaces with VoIP / SIP phone
systems.

Light Sensor

Auto-dimming display.

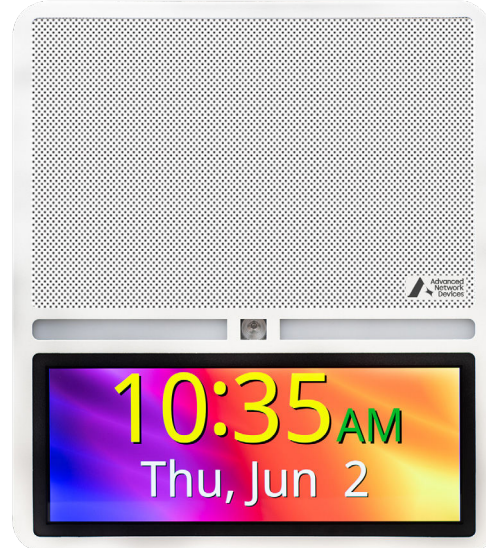

Product Overview

Engage and capture attention with the PoE+ IP Speaker with HD Display. Employ custom graphics and images for day-to-day and critical announcements using the high-resolution LCD display, RGB flashing bar, and 8 inch speaker.

The IPSWDHD-MW is typically installed in classrooms or any average sized room, easily integrates with VoIP phone systems, approved 3rd party software, and includes ClockWise Campus software with purchase.



Dimensions

(Dimensions are subject to change.)

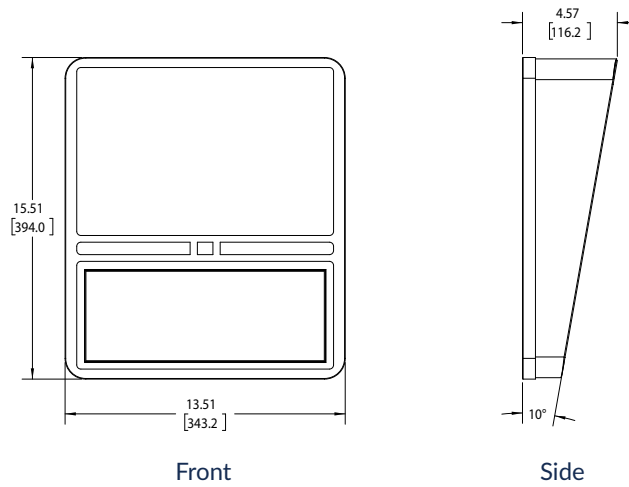

Specifications

Category	Specifications
Power Input	PoE+ (IEEE802.3at) 30.0W
Ethernet Interface	10/100/1000 Mbps
Speaker Size	8"
Frequency Response	60 Hz - 17 kHz
Audio Payload Types	G.711 A-law and μ -law, G.722, PCM
Average Sensitivity	95dB, 1W / 1 M
Supported Protocols	SIP, IPv4, IPv6, 802.1X, HTTP, SLP, TFTP, NTP, SNMPV1 & SNMPV2c, DHCP, IGMP, ICMP, TCP/IP, LLDP-MED, UDP, MDNS & MDNS-SD
General Purpose Interface	2 GPI: 1 via 6P6C RJ-12, 1 on-board, Phoenix connector via bare wire 1 GPO: Contact Closure or 21.6 VDC
Audio Interface	Stereo Analog Line Out Stereo Analog Line In
Operating Temperature	14° TO 122° F (-10° TO 50° C)
Dimensions	13.51" W x 15.58" H x 4.54" D
Weight	10.5 lbs (4.7 kg)
Warranty	6 Year Limited*

(Due to continual product development, specifications are subject to change without notice)

*Applies to eligible ANetD hardware devices purchased on or after February 1, 2026. See warranty for details.



Contact Us

- 847.463.2236
- sales@anetd.com
- 3820 N Ventura Drive
Arlington Heights, IL 60004
- anetd.com

