

PART NUMBER
AND-STROBE-KIT-1

CATEGORY
STROBES

Features

Analog Integration

Activate strobe by connecting to contact closure, call button, existing security system, etc.

Software

ClockWise Campus software included. Compatible with approved third-party software.

SIP Integration

SIP ring detection alert.



Product Overview

Provide an additional mode of emergency notification or alert messaging by connecting the ANetD Strobe KIT (AND-STROBE-KIT-1) to a compatible ANetD IP endpoint.

Once connected to an ANetD IP endpoint, the AND-STROBE-KIT-1 easily integrates with VoIP phone systems, approved third-party software, and includes ClockWise Campus software with purchase.

Contact Tech Support if you plan to connect the strobe to the IPSIGNAL-RWB. This requires the AND-PIA-2D, which will be provided at no additional cost. Contact tech@anetd.com or 847-463-2237

Dimensions

(Dimensions are subject to change.)

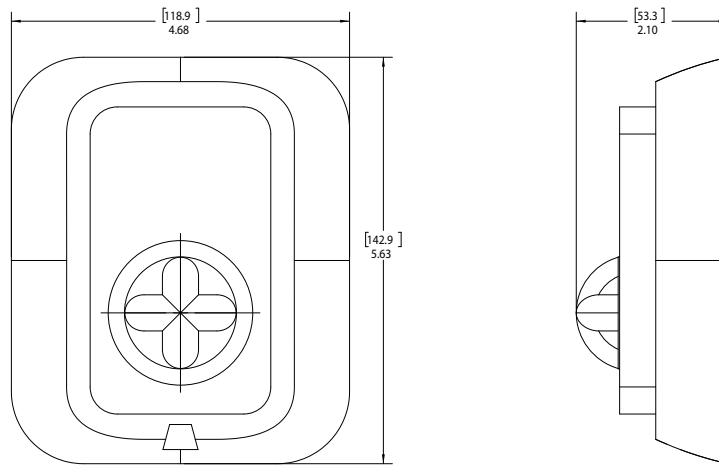

Front

Side

Category	Specifications
Power	Powered by connected AND device
Ethernet I/F	10/100 Mbps
Flash Rate	1 Flash per second
Luminous Intensity	15/75 Candela
Humidity Range	10 to 93% Non-condensing
Operating Temperature	32° TO 120° F (0° TO 49° C)
Dimensions	4.65" W x 5" H x 2.75"D
Weight	2 lbs (0.91 kg)
Warranty	6 Year Limited*

(Due to continual product development, specifications are subject to change without notice.)

*Applies to eligible ANetD hardware devices purchased on or after February 1, 2026. See warranty for details.



Contact Us  847.463.2236
 sales@anetd.com
 3820 N Ventura Drive
Arlington Heights, IL 60004
 anetd.com

